

# C167CR EvaBoard

The C167CR EvaBoard is a micro controller board for CAN-based networks that enables rapid prototyping with pre-tested working boards.

EvaBoards include all hardware and software components for first application steps, including download of test software via RS232 from the PC. Operating software is included in an EPROM and can be controlled by on-board DIP-switches.

The micro controller I/O lines and parallel bus lines are accessible through standard connectors and enable first

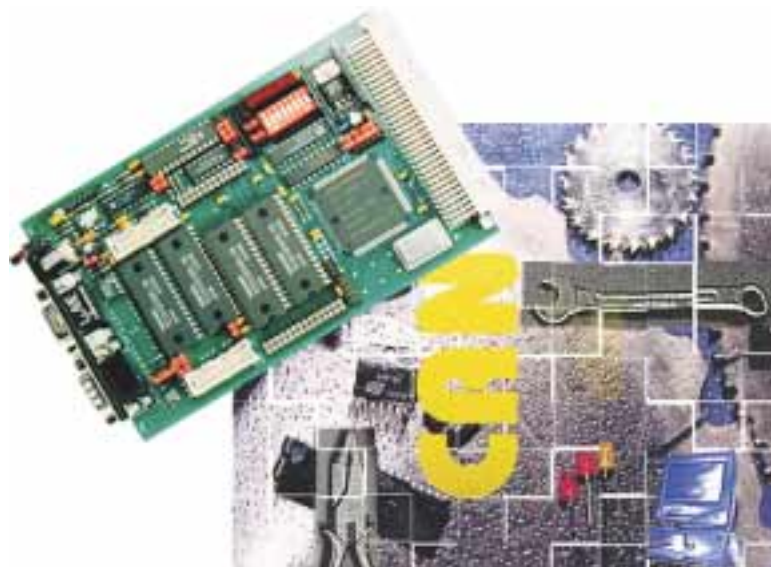

## FEATURES

- Application scope: learning, prototyping, testing, control of network systems.
- Application area: real-time process control with/without intercommunication through a network; stand-alone controller operation and/or PC-controlled operations; fast data acquisition; etc.
- Eva-PC-Control software lets you manipulate the network protocol chip registers, transmit and receive messages and download user-specific programs from the PC into the Evaboard for execution.

## HIGHLIGHTS

- Operates in stand-alone or PC-controlled mode, coupled through RS232 interface.
- Control program resident in EPROM; can be controlled by on-board DIP-switches
- Software service for resetting the protocol chip hardware.
- Optional transceivers and protocol plug-in modules adapt basic boards to a variety of applications.
- Each board provides EPROM, RAM, DIP-switches, LEDs and connectors for the various interfaces, the processor I/Os and the parallel micro controller address, data and control lines.
- LevelX, API for easy programming CAN applications
- PcCANControl, software tool

# Eva Board

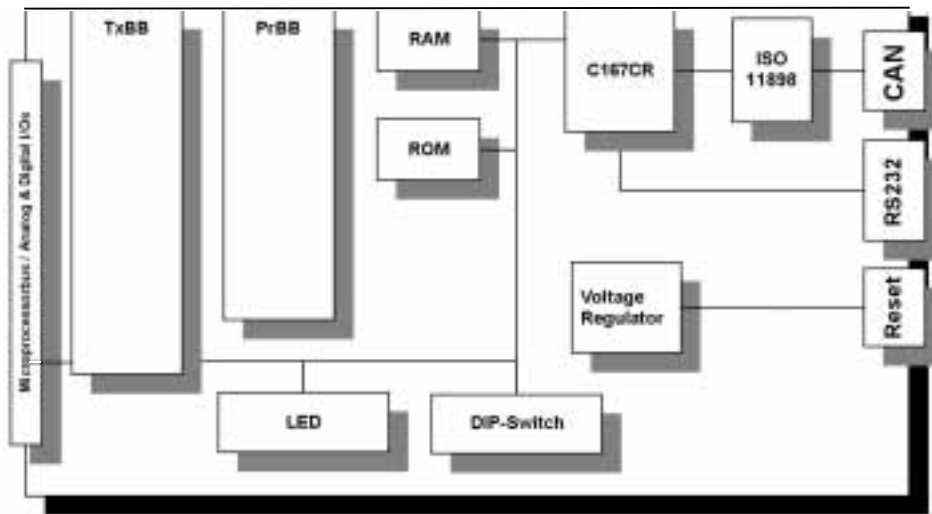

## SPECIFICATIONS

### General Characteristics

- Physical dimensions: EuroBoard  
100 mm x 160 mm
- Power supply: External 8 to 12 VDC  
typical 500 mA with  
on-board voltage regulator
- Power consumption: Depending on the  
processor type, protocol  
and physical transceiver
- Temperature range: 0 to +70° C
- Processor types: C167CR, @ 20 MHz
- Memory: 2 x 256 EPROM (16Bit)  
2 x 128 SRAM (16Bit)
- FLASH\*\*: 2 x 128 Flash (16Bit)  
(include sockets)

### Connectors

- Power supply: Mini-socket per DIN 45232
- Network: 9-pin Sub-Min-D CiA standard
- RS232: 9-pin Sub-Min-D 57,6 KB/s
- Processor parallel bus and I/O lines
- EuroBoard size connector\*\*: 160-pin DIN 41612 VG

### Network protocol interfaces

- Internal: C167CR CAN 2.0B core
- Optional external: S-FullCAN, BasicCAN,  
FullCAN, Extended-CAN,  
J1850-DLC / HBCC

### Network physical interfaces

- Internal: ISO 11 898 (82C250)
- Optional external: ISO 11 898 (82C250),  
RS485 standard,  
J1850-DLC / HBCC,  
fiber optics, gal. decoupled  
biphasedifferential,  
prototyping etc.
- Optional add-ons: On-board mem. expansion,  
Flash EPROM,  
professional developers' kit  
for programming of the  
micro controller

\*\* = not included the small edition.

## GENERAL INFORMATION

- Hardware requirements:
  - PC-compatible
  - External power supply
  - RS232C interface
- Software requirements:
  - MS-DOS 3.0 or higher
  - Windows (see "product includes")
  - Compiler for software development
- Knowledge requirements for design of own  
applications :
  - Experience in programming PCs and  
Micro controllers (assembly language or C )
  - Network protocol

## PRODUCT INCLUDES

- C167CR EvaBoard, including on-board control  
software
- Manual and circuit diagram
- PcCANControl software and  
LevelX drivers for Win 9x, NT, 2000

## ORDERNUMBERS

- IME 2308 204 C167CR Evaboard Small edition
- IME 2308 205 C167CR Evaboard