



CAN I/O

The CAN I/O's are primarily intended as hardware for distributed industrial control application. They can also be used as a stand alone controller.

The CAN interface enables CAN I/O to participate in a real time network. Complex control algorithms can be distributed among several decentralized stations with a minimum of wiring.

The core of the CAN I/O's consists of different micro controller (Philips 80C592 / Siemens 80C166 with external CAN cell and Siemens SAB C167 CR), which has FlashEPROM onboard and up to 256 kByte EPROM.

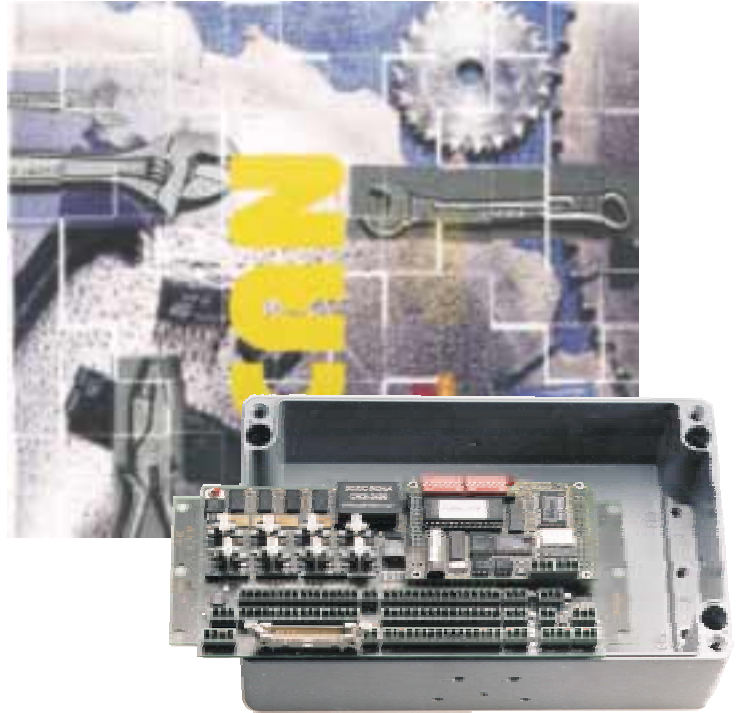

FEATURES

- Up to 64 I/O (32 digital in and 32 digital out)
- Analog in- and outputs and programmable counter are available.
- CAN protocol according to CAN 2.0A by using the 8-Bit version and CAN 2.0B by using the 16-Bit version
- On board RS 232 interface for easy development, diagnostic and service.
- Ideal platform for real time I/O management
- Flexible interfacing of various types of digital I/Os
- Data (pre-)processing by the microcontroller or direkt link of input event to CAN
- CANopen supported

HIGHLIGHTS

- Easy configuration and easy to use
- Designed for rough industrial environment
- Configurable via CAN or RS232
- Different housing for various protection classes available
- reduces the wiring
- PC program for remote control
- Slave board with 32 I/Os available
- All in- and outputs with phoenix contact connectors
- Delivery content includes documentation

Type 1 Digital and Analog I/O

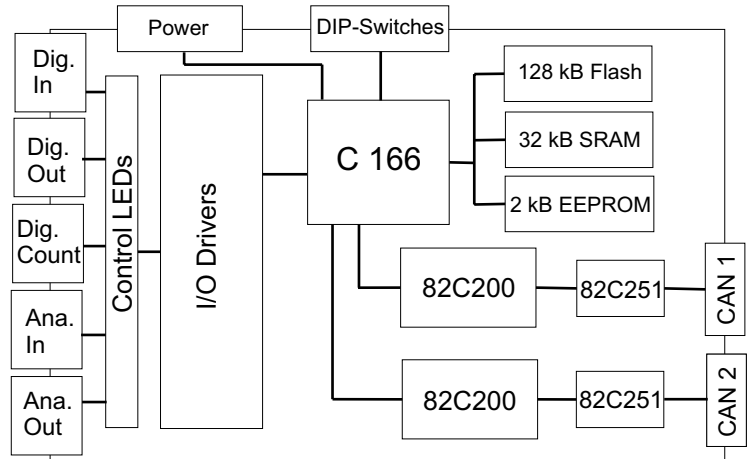
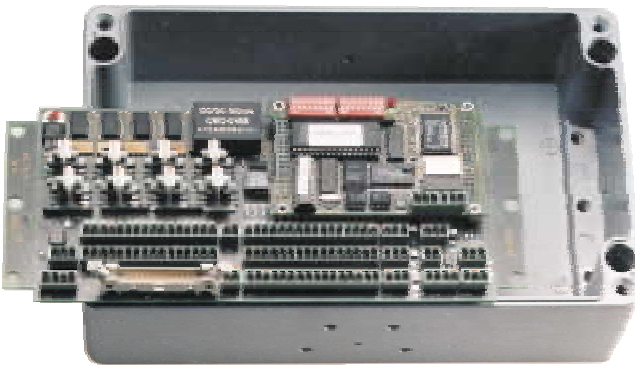

SPECIFICATIONS

General Characteristics

- Transfer rate CAN: up to 1 MBit/s
- Physical dimensions: 240 mm x 100 mm
- Housing: on request
- Power supply: 24 V DC
- Temperature range: 0 to +70° C
- Processor types: C166, @ 40 MHz
- Memory: 2 kByte EEPROM
32 kByte SRAM
(opt. 128 kByte)
128 kByte Flash
- I/Os: 16 digital inputs 24 VDC
(with protection)
16 digital outputs 24 VDC
(500mA/channel, Highsideswitch)
3 programmable counter
(inputs)
1 analog input 0-10V
(10 Bit resolution)
1 analog output 0-10V
(8 Bit dissolution.)

Connectors

- Network CAN1/2: Phönix Contact (Combicon)
- I/Os: Phönix Contact (Combicon)
- Power supply: Phönix Contact (Combicon)

Network protocol interfaces

- CAN: Philips SJA 1000 CAN 2.0B

Network physical interfaces

- CAN: CAN ISO 11 898 (82C251)

PRODUCT INCLUDES

- 1 x CAN I/O Type 1 hardware
- Universal I/O firmware in Flash
- Short description

ORDERNUMBERS

- IME 1801 401 Development Set
- IME 1801 201 Hardware
- IME 1801 402 Hardware + CANopen SW